

Analogue display with stepper motor

- For use in ships and rail vehicles
- Typical applications:
Thrust direction and rudder position display
- Propeller adjustment angle, RPM display and speedometer
- LED scale and indicator illumination
- Accuracy class 0.5
- Non-sensitive to shocks and vibrations
- General purpose use





Analogue display with stepper motor

SM 72-270°
SM 96-270°
SM 144-270°



SM 72, SM 96, SM 144 analogue display

This device series has been developed mainly for use in ships and rail vehicles.

Typical applications are the display of thrust direction and rudder position with POD drives, display of the propeller adjustment angle of CPP propellers, machine and propeller RPM, temperature, pressure, speed and other physical values.

Highlevel accuracy is guaranteed, even in extreme environmental conditions.

Analogue display in stepper motor technology, comprising a stepper motor with indicator and the necessary input and control electronics.

Technical Data

Supply voltage: 18 ... 36 V DC
Power consumption: < 1.5 VA
Starting current: 1 A about 1 sec.

Electrical security

Overvoltage category: CAT III EN 61010-1:2001
Working voltage: 50 V EN 61010-1:2001
Protection class: IP 56 Front panel EN 60529
IP 20 Terminals EN 60529
Electromagnetic compatibility: EMC Standart 89/336 EWG/EEC
EN 61326:2004
Shock level: 30 g DIN EN 60 051
Vibration level: 5.0 g DIN EN 60 051

Range of application (Climatic demands)

Humidity: ≤ 75% (at 21 °C) annual mean
≤ 95% (at 25 °C) 30 days per year
≤ 85% (at 23 °C) remaining days
Operating temperature: -25°C ... +55 °C
Storage temperature: -25°C ... +65 °C

Electrical characteristic values

Input: 0-20 mA, 4-20 mA, ± 20 mA, 0-10 V, ± 10 V DC
Input resistance: I DC about 100 Ω, U DC 1 MΩ
BUS: CAN OPEN (Option)
Illumination: LED, 24V DC with dimmer for scale and pointer
Stepping motor: Gear motor, with resolution of 0.083°
(4320 step)
Rotation speed: max. 1.5 sec./360°
Accuracy: class 0.5
Linearity failure: ± 1°

Housing

Material: Steel plate, hot-dip galvanized
Frontframe: Plastic, black
Glass face plate: Antirglare flood glass (flat glass)
Mounting position: any
Weight: 280 g (SM 72-270°), 420 g (SM 96-270°),
710 g (SM 144-270°)
Mounting fasteners: Screw fasteners
Scale design: to be made to customer's specification
Option: Pointer position reflection at 180°
by closing a free of potential-contact

Special feature:

The devices are calibrated in the factory. The USB connection is used for customer-specific adjustments, with which the zero setting as well as the initial and final values can be calibrated as required by the customer, by means of the calibration programme.





Analogue display with stepper motor

SM 72-360°
SM 96-360°
SM 144-360°



The advantage over moving-coil systems is the much greater mechanical stability. Guaranteed non-sensitive to shocks and vibrations in continuous operation. Developed according to state-of-the-art technology, the electronic design enables easy connection to CAN BUS applications or other BUS systems as well as the processing of standard signals, for example 0–10 V or 0/4–20 mA or double-slide potentiometers. Selectable display ranges from 0–90° to 0–360°.

The adjustable scale and indicator illumination (PBM) guarantees correct instrument read-out in the most variable light situations.

Technical Data

Supply voltage: 18 ... 36 V DC
Power consumption: < 1.5 VA
Starting current: 1 A about 1 sec.

Electrical security

Overvoltage category: CAT III EN 61010–1:2001
Working voltage: 50 V EN 61010–1:2001
Protection class: IP 56 Front panel EN 60529
IP 20 Terminals EN 60529
Electromagnetic compatibility: EMC Standart 89/336 EWG/EEC
EN 61326:2004
Shock level: 30 g DIN EN 60 051
Vibration level: 5.0 g DIN EN 60 051

Range of application (Climatic demands)

Humidity: ≤ 75% (at 21 °C) annual mean
≤ 95% (at 25 °C) 30 days per year
≤ 85% (at 23 °C) remaining days
Operating temperature: –25°C ... +55 °C
Storage temperature: –25°C ... +65 °C

Electrical characteristic values

Input: 0–20 mA, 4–20 mA, ± 20 mA, 0–10 V, ± 10 V DC
Input resistance: I DC about 100 Ω, U DC 1 MΩ
BUS: CAN OPEN (Option)
Illumination: LED, 24V DC with dimmer for scale and pointer
Stepping motor: Gear motor, with resolution of 0.083°
(4320 step)
Rotation speed: max. 1.5 sec./360°
Accuracy: class 0.5
Linearity failure: ± 1°

Housing

Material: Steel plate, hot-dip galvanized
Frontframe: Plastic, black
Glass face plate: Antirglare float glass (flat glass)
Mounting position: any
Weight: 280 g (SM 72–360°), 420 g (SM 96–360°),
710 g (SM 144–360°)
Mounting fasteners: Screw fasteners
Scale design: to be made to customer's specification
Option: Pointer position reflection at 180°
by closing a free of potential-contact

Special feature:

The devices are calibrated in the factory. The USB connection is used for customer-specific adjustments, with which the zero setting as well as the initial and final values can be calibrated as required by the customer, by means of the calibration programme.



Connections and Dimensional Drawing

Connections:

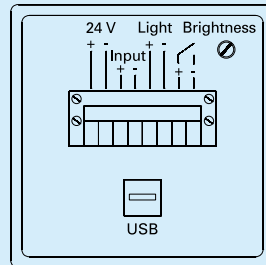

Dimensional Drawing:

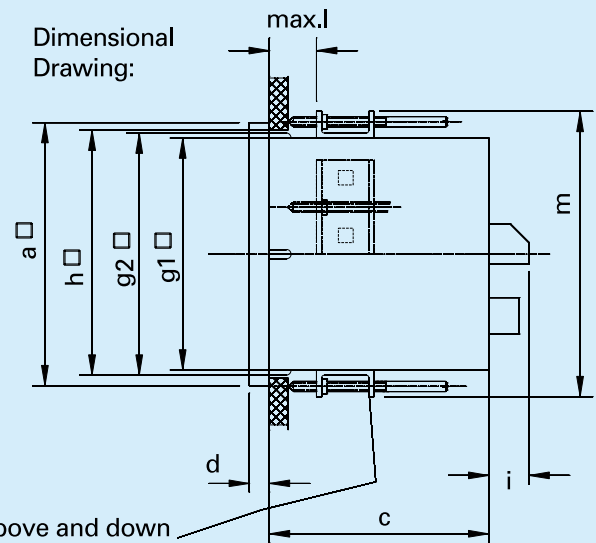

Device mounting above and down or on the left and on the right

Type:	a □	g1 □	g2 □	c	d	m	max.l	i	Cutout h □
SM 72	72	66	67,5	70	5,5	82	15	7	68+0,7 x 68+0,7
SM 96	96	90	91,5	53	5,5	106	16	11	92+0,8 x 92+0,8
SM 144	144	136	137,5	57	7,5	152	14	13	138+1 x 138+1

Analogue display units
 Measuring transducers
 Digital measuring instruments
 Appliance testers
 Contact devices
 Text displays / printers
 Bar graph displays
 Probes
 Accessories



Product Table



Gilgen Müller & Weigert

Am Farnbach 4A
 D-90556 Cadolzburg, Germany
 Tel.: +49 (0)9103 7129-0
 Fax: +49(0)9103 7129-205
 www.g-mw.de
 info@g-mw.de