

CCT 41.4 I (Compensation current transformer, GMW All current sensors) Current transformers for the measurement of direct and alternating currents

- For network analysis, monitoring,
- and measuring of non-sinusoidal and distorted networks

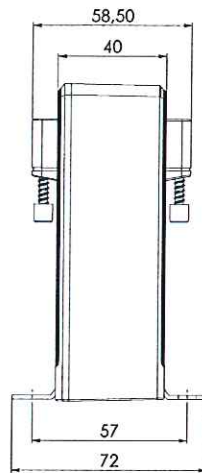

Additional accessories:
Snap-on mounting to clip onto
35 mm DIN rail (Art.-no. 52012)

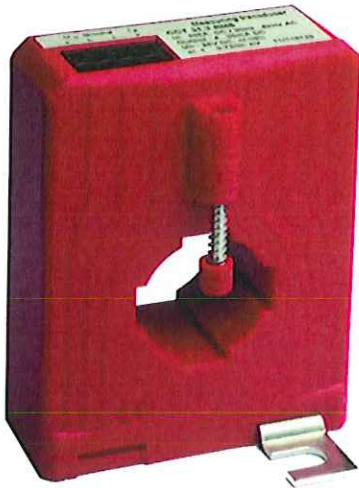
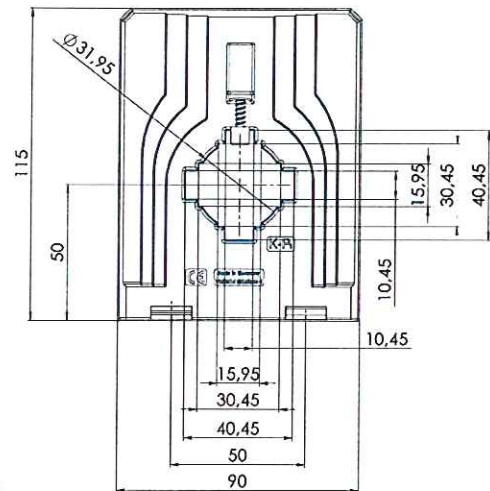

Dimensions:

Bus bar 1: 40x10 mm
Bus bar 2: 30x15 mm
Round conductor: 31,5 mm
Transformer width: 90 mm
Transformer height: 115 mm
Transformer depth: 58,5 mm

Applicable technical standards:

DIN EN 50178, 1997
DIN EN 61010-1, 2002
VDE 0160

Electric connections:

$U_H + 0$ (Ground) I_A
Spring clamp terminal
Connection cross sections: 0.08...2.5 mm²

Technical data:

Measuring range:	0...500 A DC / AC I_{eff} , depends on varieties! (Nominal current ranges adjusted to standard values according to IEC)
Frequency range:	0... 100 kHz, any signal curves
Current output at AC-input signal:	AC: 0...20 mA I_{eff} , (± 28.2843 mA I_{Peak})
Current output at DC-input signal:	DC: 0... ± 20 mA
Max. burden resistance at current output:	$R_B \leq 200 \Omega$ ($U_H = 24$ V DC)
Current limit under overload:	< 25 mA
Accuracy:	$\pm 0,5$ %
Max. operating voltage U_m :	0,72 kV, U_{eff}
Isolation test voltage:	6,4 kV, U_{eff} , 50 Hz, 5 sec., primary conductor against measuring output / housing
Auxiliary voltage:	± 12 V DC, $\pm 15\%$ < 70 mA, external protection via microfuse 100 mA / 250 V, fast!
Energia response time (90 % I_{PN} , $di/dt = 100$ A / μs):	$\leq 1 \mu s$ (typ. 150 ns)
Signal rise velocity di/dt :	< 100 A / μs
Isolation class	E
Protection class	IP 20
Operating altitude	≤ 2000 m (DIN EN 61010-1)
Max. temperature of the primary conductor:	100° C
Operating temperature:	-25° C < T_U < +60° C, 0...95% rH, without condensation
Storage temperature:	-40° C < T_L < +90° C

Gilgen, Müller & Weigert (GMW) GmbH & Co. KG

Am Farrnbach 4A · 90556 Cadolzburg
Germany

Phone: +49 9103 7129-0 · Fax: +49 9103 7129-207/ -205
E-Mail: info@g-mw.de · Web: www.g-mw.de

Functions of the CCT 41.4 I:

- Electricity is conducted over the magnetic field and is captured by the measuring core. The current induced in the measuring core is proportional to the magnetic flow and is captured by a semi-conductor element. An integrated electronic control unit converts the semi-control signal to a value of the measuring size in proportion to the DC output current signal.
- A contactless inductive captured parameter creates a galvanically separated output signal.
- Electrical contact with the secondary circuit of the current transformer is achieved by means of a 4-pole-spring-clamp. This clamp is suitable for connection to a flexible conductor up to 2.5 mm².
- A DC auxiliary voltage of ± 12 V is required to supply the electronic controls. The auxiliary voltage input must be secured by a HRC fuse size of 100 mA / 250 V microfuse.

Advantages and benefits of the CCT 41.4 I:

- Measuring of direct current as well as alternating current with only one current transformer is possible.
- Large working frequency range from 0 Hz (DC)... 100 kHz (AC).
- High electric protection of the galvanically isolated capture of the measured variable.
- Low power-consumption (≤ 2.5 VA)
- Easy and safety electrical connection by means of spring clamp terminal.
- Direct mounting onto the bus bar by means of integrated fixing screws which are part of the unit.
- Mounting onto 35 mm DIN-rail by means of optional supply of snap-on mounting.
- High climatic and mechanical durability, PU-resin hardened enclosures of all electrical components.

Transfer ratio of the CCT 41.4 I:

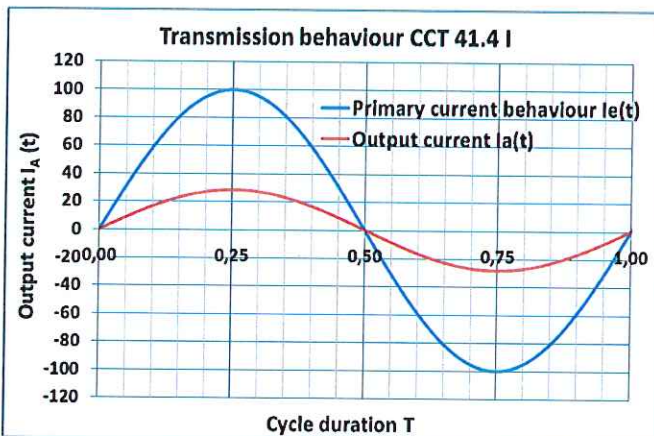

Wiring Diagram of the CCT 41.4 I:

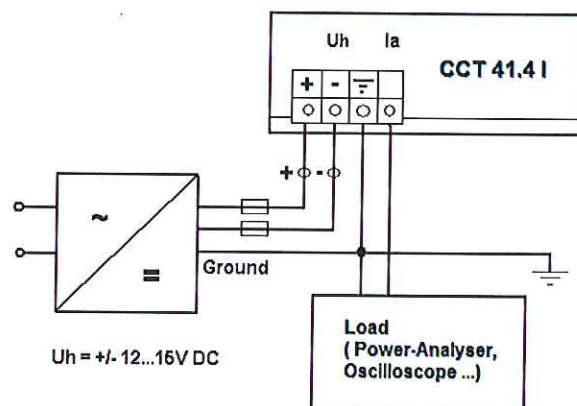

Order list:

Type	Primary current [A] DC / AC (I_{eff})	Art.-no.	Current output
CCT 41.4 I	150	1201-10005	DC: 0...± 20mA AC: 0...20 mA I_{eff}
	200	1201-10006	
	250	1201-10007	
	300	1201-10008	
	400	1201-10009	
	500	1201-10010	