

## CCT 41.4 RMS (Compensation current transformer, GMW All current sensors)

### Current transformers for the measurement of direct and alternating currents

- For measuring of non-sinusoidal and distorted networks
- As a measuring transducer for the direct input wiring of SPS input cards

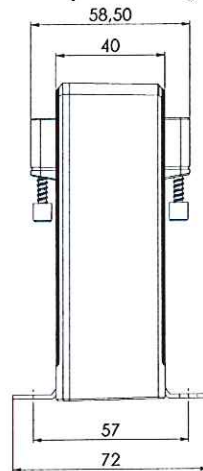
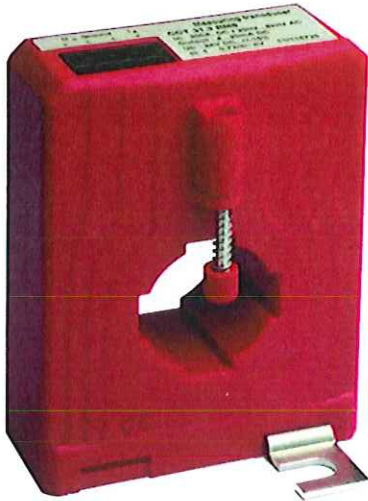

**Additional accessories:**  
Snap-on mounting to clip onto 35 mm DIN rail (Art.-no. 55012)

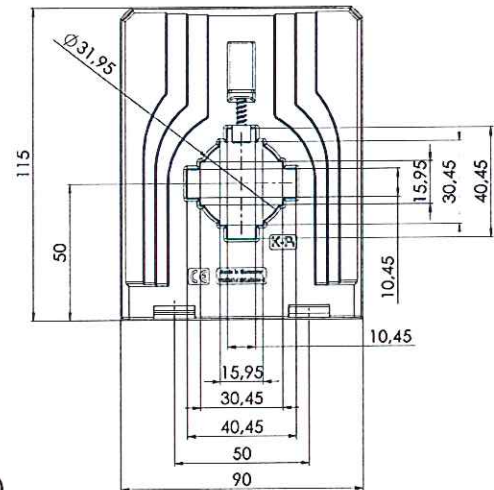

#### Dimensions:

Bus bar 1: 40x10 mm  
Bus bar 2: 30x15 mm  
Round conductor: 31,5 mm  
Transformer width: 90 mm  
Transformer height: 115 mm  
Transformer depth: 58,5 mm

#### Applicable technical standards:

DIN EN 50178, 1997  
DIN EN 61010-1, 2002  
VDE 0160

#### Electric connections:

$U_H + 0$  (Ground)  $I_A$   
Spring clamp terminal  
Connection cross sections: 0.08...2.5 mm<sup>2</sup>

#### Technical data:

Measuring range:	0...500 A DC / 0...500 A I <sub>RMS</sub> AC, depends on varieties! (Nominal current ranges adjusted to standard values according to IEC)
Frequency range:	DC, or AC 20 Hz ... 6 kHz, Crest-factor ≤ 4
Current output:	4...20 mA DC, RMS measurement
Max. burden resistance at current output:	$R_B \leq 500 \Omega$ ( $U_H = 24$ V DC)
Current limit under overload:	< 25 mA
Accuracy:	± 1,0 %
Max. operating voltage $U_m$ :	0,72 kV, $U_{eff}$
Isolation test voltage:	6,4 kV, $U_{eff}$ , 50 Hz, 5 sec., primary conductor against measuring output / housing
Auxiliary voltage:	24 V ± 15 % DC, < 70 mA, external protection via microfuse 250 mA / 250 V, fast!
Step response time (90 % I <sub>PN</sub> , di/dt = 100 A / μs):	≤ 200 ms (typ. 150 ms)
Signal rise speed di/dt:	< 100 A / μs
Isolation class	E
Protection class	IP 20
Operating altitude	≤ 2000 m (DIN EN 61010-1)
Max. temperature of the primary conductor:	100° C
Operating temperature:	-25° C < T <sub>U</sub> < +60° C, 0...95% rH, without condensation
Storage temperature:	-40° C < T <sub>L</sub> < +90° C

### Gilgen, Müller & Weigert (GMW) GmbH & Co. KG

Am Farnbach 4A · 90556 Cadolzburg  
Germany

Phone: +49 9103 7129-0 · Fax: +49 9103 7129-207/ -205  
E-Mail: info@g-mw.de · Web: www.g-mw.de

### Functions of the CCT 41.4 RMS:

- Electricity is conducted over the magnetic field and is captured by the measuring core. The current induced in the measuring core is proportional to the magnetic flow and is captured by a semi-conductor element. An integrated electronic control unit converts the semi-control signal into a true effective value of the measuring size in proportion to the DC output current signal. The true effective value is calculated by the delta-sigma-method.
- A contactless inductive captured parameter creates a galvanically separated output signal.
- Electrical contact with the secondary circuit of the current transformer is achieved by means of a 4-pole spring-clamp. This clamp is suitable for connection to a flexible conductor up to 2.5 mm<sup>2</sup>.
- A DC auxiliary voltage of 24 V is required to supply the electronic controls. The auxiliary voltage input must be secured by a HRC fuse size of 250 mA / 250 V/F.

### Advantages and benefits of the CCT 41.4 RMS:

- Measuring of direct current as well as alternating current with only one current transformer is possible.
- Exact calculation of the true effective value of any temporal process of the current which is to be measured.
- Large working frequency range from 0 Hz (DC) or 20 Hz...6 kHz (AC).
- High electric protection of the galvanically isolated capture of the measured variable.
- Low power-consumption ( $\leq 2.5$  VA)
- Easy and safety electrical connection by means of spring clamp terminal.
- Direct mounting onto the bus bar by means of integrated fixing screws which are part of the unit.
- Mounting onto 35 mm DIN-rail by means of optional supply of snap-on mounting.
- High climatic and mechanical durability, PU-resin hardened enclosures of all electrical components.

### Transfer ratio of the CCT 41.4 RMS:

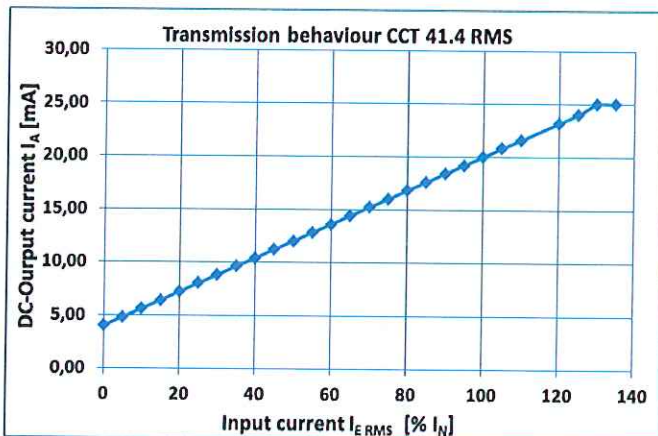

### Wiring Diagram of the CCT 41.4 RMS:

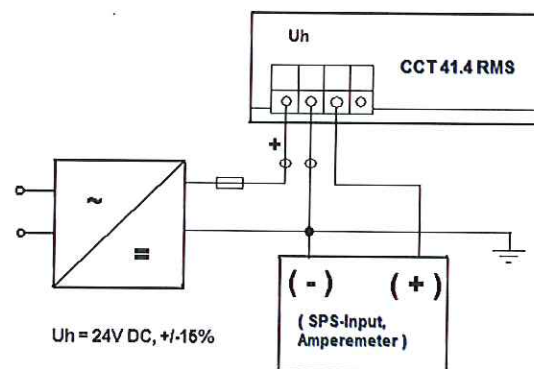

### Order list:

Type	Primary current $I_{RMS}$ [A]	Art.-no.	Current output
CCT 41.4 RMS	150	1203-10005	4...20 mA DC
	200	1203-10006	
	250	1203-10007	
	300	1203-10008	
	400	1203-10009	
	500	1203-10010	